

| REVISIONS |     |             |            |            |
|-----------|-----|-------------|------------|------------|
| ZONE      | REV | DESCRIPTION | DATE       | APPROVED   |
|           | A   | RELEASED    | 01/04/2000 | B. RABBITT |

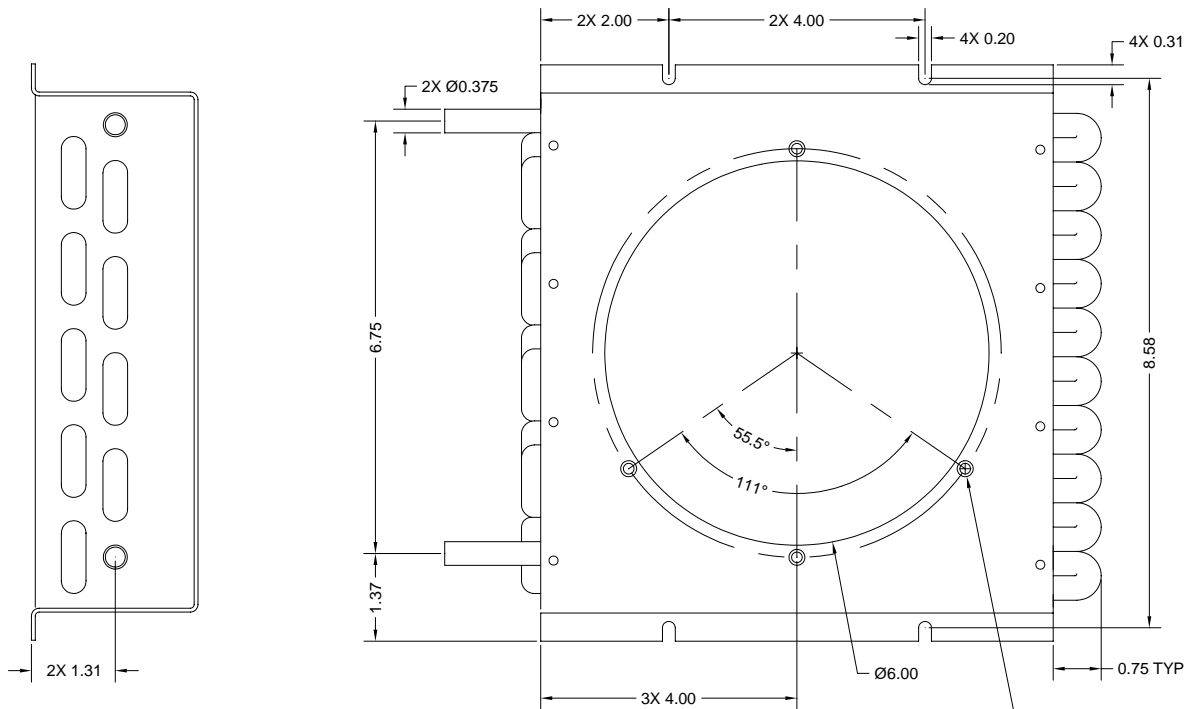

4X 6-32 THREADED INSERTS  
POSITIONED AS SHOWN ON  
A Ø6.375 BC ±0.10

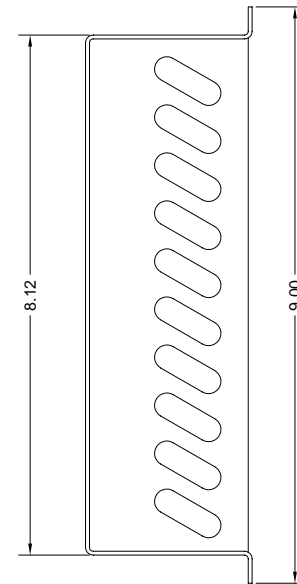
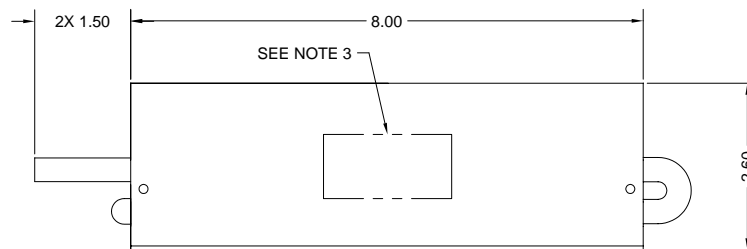

- NOTES:
1. PRESSURE TEST ASSEMBLY AT 150 PSI.
  2. TUBE TREAT PER TEI 101-07. BRIGHTEN FINS PER PROCEDURE.
  3. APPLY LABEL AS SHOWN AND MARK WITH MODEL NO. AND DATE OF MANUFACTURE.

|   |   |                            |   |
|---|---|----------------------------|---|
| <b>CONFIDENTIAL INFORMATION</b>   | DRAWN BY: J. RUBITSKI                                 | DATE: 01/04/2000           | <b>THERMATRON ENGINEERING Inc.</b><br>687 LOWELL STREET, METHUEN MA 01844 * PHONE: (978) 687-8844 FAX: (978) 687-8844<br>E-Mail: RFP@THERMATRONENGL.COM * Web Site: HTTP://WWW.THERMATRONENGL.COM |
|   | CHECKED BY: B. RABBITT                                | DATE: 01/04/2000           |   |
| THIS DRAWING CONTAINS INFORMATION THAT IS RESTRICTED. USE OF THE INFORMATION CONTAINED HEREIN WITHOUT THE EXPRESS CONSENT OF THERMATRON ENGINEERING IS STRICTLY PROHIBITED. | APPROVED BY: B. RABBITT                               | DATE: 01/04/2000           | TITLE: <b>HEAT EXCHANGER</b>  |
| REFERENCE No.:  | UNLESS OTHERWISE SPECIFIED, DIMENSIONS ARE IN INCHES. | TOLERANCE                  | CODE INDENT. No. <b>1GQ06</b> DRAWING No. <b>732SLP0</b> DRAWING SIZE <b>C</b>  |
| NEXT ASSEMBLY:  | DECIMALS: .XX ± 0.015                                 | ANGLES: .XXX ± 0.010 ± 1/2 | THIRD ANGLE PROJECTION  |
|   |   |                            | SCALE: 1:1 SHEET: 1 OF 1  |